



# SILICONE NEON STRIP

PRODUCT SPECIFICATION

**RLLNFSB1220E** Sided view



- High light transmittance, environmental protection grade silicone material, integrated extrusion molding process.
- Unique optical light distribution structure design, uniform lighting surface and no shadow.
- IP44 protection level, salt solution resistance, acids & alkalis and UV resistance
- Excellent toughness, simple and stylish appearance, delicate and unique.
- 3 years warranty, working life  $\geq 30000$  hours.

### Dimension structure

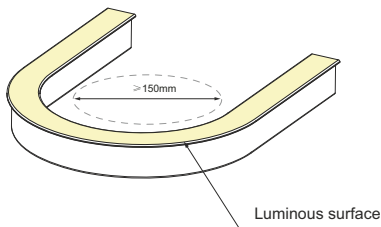
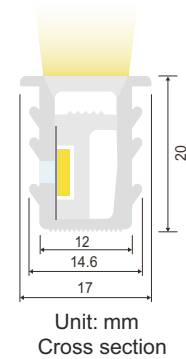
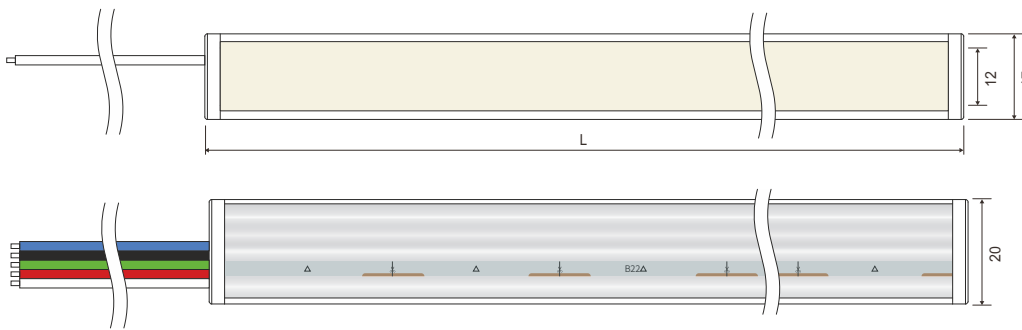

Min bending diameter

### Electrical Parameter

Voltage	LED PIN Temperature	Storage Temperature	Ambient Temperature	CRI
DC24V	Max. 65 C	25 C ~ 60 C	Min. 25°C Max(Table below)	$\geq 90$

### Specification

Power(w/m)	Efficacy(lm/w)@4000K	Max Ambient Temperature
10 w/m	40.7 lm/w	45°C

Due to the tolerance of the production and electrical components, output value and electrical power can vary up to 10%

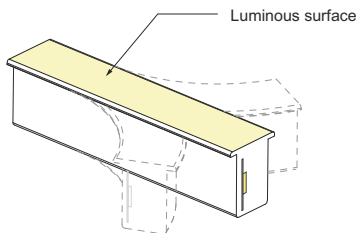

Bend horizontal only

### Length Standard

Length Range (M)	Final Length	Tolerance(mm)
0M < Neon Strip(L) $\leq$ 5M	L+6	$\pm 7$
5M < Neon Strip(L) $\leq$ 10M	L+6	$\pm 10$
10M < Neon Strip(L) $\leq$ 15M	L+6	$\pm 13$
15M < Neon Strip(L) $\leq$ 20M	L+6	$\pm 16$



- The maximum series length refers to the maximum single end power supply length of the constant current strip under the condition of standard 20CM wire .
- The given color temperature is the temperature of finished product.
- The given data are typical values due to the tolerance of the production process and the electrical components, values for light output and electrical power can vary up to 10%.
- All products can be dimmed; the dimmer' s voltage should conform to the rated voltage of the led light. The output frequency of the dimmer of the constant-current led light should be less than 2K Hz, and the output PWM can control the led light.

### Single color (Lm/m)

CCT(K)	CRI	Voltage	Power(W)	Lumen (LM/M)	Efficiency (LM/W)	Unit Length (mm)	Max. Run Length (M)	CC/CV
2400K $\begin{smallmatrix} +150 \\ -50 \end{smallmatrix}$	>90	DC24V	10	374	37.4	50	17(CC)	CC/CV
2700K $\pm$ 100	>90	DC24V	10	365	36.5	50	17(CC)	CC/CV
3000K $\pm$ 150	>90	DC24V	10	370	37	50	17(CC)	CC/CV
4000K $\pm$ 200	>90	DC24V	10	407	40.7	50	17(CC)	CC/CV
5800K $\begin{smallmatrix} +300 \\ -200 \end{smallmatrix}$	>90	DC24V	10	378	37.8	50	17(CC)	CC/CV
R	--	DC24V	10	169	16.9	50	18(CC)	CC/CV
G	--	DC24V	10	427	42.7	50	17(CC)	CC/CV
B	--	DC24V	10	98	9.8	50	17(CC)	CC/CV
Yellow	--	DC24V	10	126	12.6	50	18(CC)	CC/CV
Orange	--	DC24V	10	167	16.7	50	17(CC)	CC/CV
Pink	--	DC24V	10	346	34.6	50	17(CC)	CC/CV

### CCT Tunable (Lm/m)

CCT(K)	CRI	Voltage	Power(W)	Lumen (LM/M)	Efficiency (LM/W)	Unit Length (mm)	Max. Run Length (M)	CC/CV
2700K $\pm$ 100	>90	DC24V	5	226	45.2	71.4	5	CV
6000K $\begin{smallmatrix} +200 \\ -300 \end{smallmatrix}$	>90	DC24V	5	241	48.2	71.4	5	CV
4000K $\begin{smallmatrix} +200 \\ -200 \end{smallmatrix}$	>90	DC24V	10	462	46.2	71.4	5	CV

### RGB (Lm/m)

CCT(K)	CRI	Voltage	Power(W)	Lumen (LM/M)	Efficiency (LM/W)	Unit Length (mm)	Max. Run Length (M)	CC/CV
R	--	DC24V	3.3	45	13.6	83.33	5	CV
G	--	DC24V	3.3	173	52.4	83.33	5	CV
B	--	DC24V	3.3	34	10.3	83.33	5	CV
RGB	--	DC24V	10	254	25.4	83.33	5	CV



- The maximum series length refers to the maximum single end power supply length of the constant current strip under the condition of standard 20CM wire .
- The given color temperature is the temperature of finished product.
- The given data are typical values due to the tolerances of the production process and the electrical components, values for light output and electrical power can vary up to 10%.
- All products can be dimmed; the dimmer' s voltage should conform to the rated voltage of the led light. The output frequency of the dimmer of the constant-current led light should be less than 2K Hz, and the output PWM can control the led light.



## RGBW

CCT(K)	CRI	Voltage	Power(W)	Lumen (LM/M)	Efficiency (LM/W)	Unit Length (mm)	Max. Run Length (M)	CC/CV
R	--	DC24V	2.5	34	13.6	83.33	5	CV
G	--	DC24V	2.5	131	52.4	83.33	5	CV
B	--	DC24V	2.5	29	11.6	83.33	5	CV
W:2400K	--	DC24V	2.5	106	42.4	83.33	5	CV
RGB	--	DC24V	7.5	193	25.7	83.33	5	CV
RGBW	--	DC24V	10	300	30.0	83.33	5	CV
R	--	DC24V	2.5	35	14.0	83.33	5	CV
G	--	DC24V	2.5	138	55.2	83.33	5	CV
B	--	DC24V	2.5	30	12.0	83.33	5	CV
W:2700K	--	DC24V	2.5	111	44.4	83.33	5	CV
RGB	--	DC24V	7.5	202	26.9	83.33	5	CV
RGBW	--	DC24V	10	314	31.4	83.33	5	CV
R	--	DC24V	2.5	34	13.6	83.33	5	CV
G	--	DC24V	2.5	132	52.8	83.33	5	CV
B	--	DC24V	2.5	29	11.6	83.33	5	CV
W:3000K	--	DC24V	2.5	107	42.8	83.33	5	CV
RGB	--	DC24V	7.5	195	26.0	83.33	5	CV
RGBW	--	DC24V	10	302	30.2	83.33	5	CV
R	--	DC24V	2.5	34	13.6	83.33	5	CV
G	--	DC24V	2.5	134	53.6	83.33	5	CV
B	--	DC24V	2.5	29	11.6	83.33	5	CV
W:4000K	--	DC24V	2.5	117	46.8	83.33	5	CV
RGB	--	DC24V	7.5	198	26.4	83.33	5	CV
RGBW	--	DC24V	10	316	31.6	83.33	5	CV
R	--	DC24V	2.5	32	12.8	83.33	5	CV
G	--	DC24V	2.5	127	50.8	83.33	5	CV
B	--	DC24V	2.5	28	11.2	83.33	5	CV
W:6300K	--	DC24V	2.5	106	42.4	83.33	5	CV
RGB	--	DC24V	7.5	187	24.9	83.33	5	CV
RGBW	--	DC24V	10	295	29.5	83.33	5	CV

## DMX512 Digital RGB

CCT(K)	Voltage	Power(W)	Lumen (LM/M)	Efficiency (LM/W)	Pixel (PCS)	Signal Type	IC Model	Unit Length (mm)	Max. Run Length (M)
R			36	9					
G	24	12	128	32	8	DMX512	SM17512	125	5
B			23	6					
RGB			178	15					

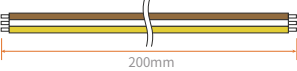
### Cable Type

Cable Type	Schematic Diagram	Specification	Core	Electrical Properties
PVC Cable		20AWG Red&Black 2 core Cable	● ●	Red V+Black V
		20AWG Brown&White&Yellow 3 core Cable	● ○ ●	Dual White: Brown V+White V&Yellow WW
		20AWG Brown&White&Yellow 3 core Cable	● ○ ●	Digital RGB: Brown V+White DI/DO&Yellow GND
		20AWG Black&Blue&Red&Green 4 core Cable	● ● ● ●	BlackV+Blue B&RedR.Green G
		20AWG Black&White&Blue&Green &Red 5 core Cable	● ○ ● ● ●	BlackV+White V&Blue B&GreenGR&RedR
20AWG Black&White&Blue&Green &Red 5 core Cable		● ○ ● ● ●	DMX512 Digital RGB: Black GND&White BI/BO&Blue AI/AO&Green PI/PO&Red V+	

### Cutting Mark

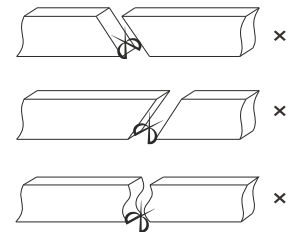

**Remark:**  
The bottom of the led strip has transparent window, the black marker is the cutting position

Use professional scissors to cut vertically at the cutting mark

Please don't be feel free to cut and cut into an oblique angle or cambered section.

### Single Color Connection Diagram

---

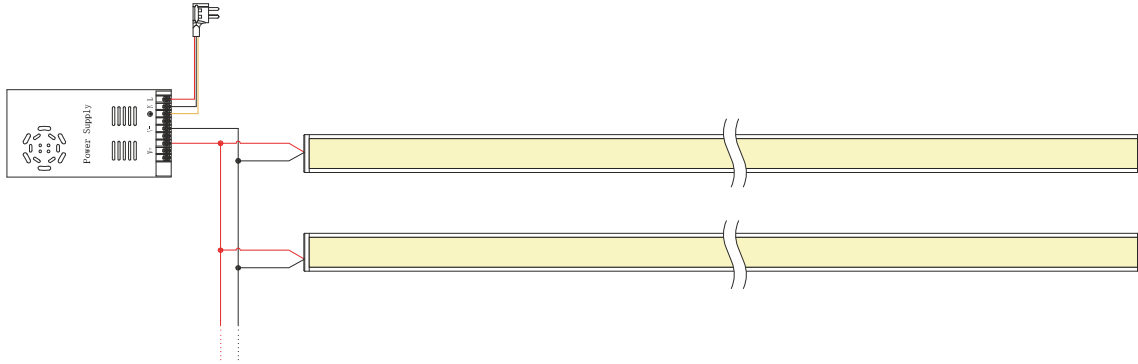

### Tunable white Connection Diagram

---

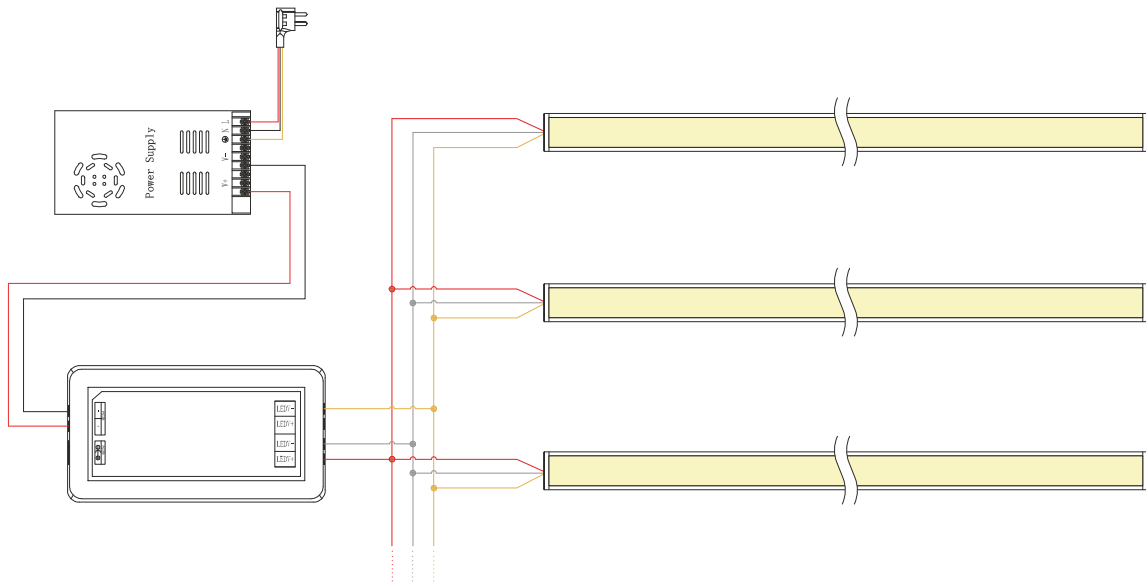

### RGB Connection Diagram

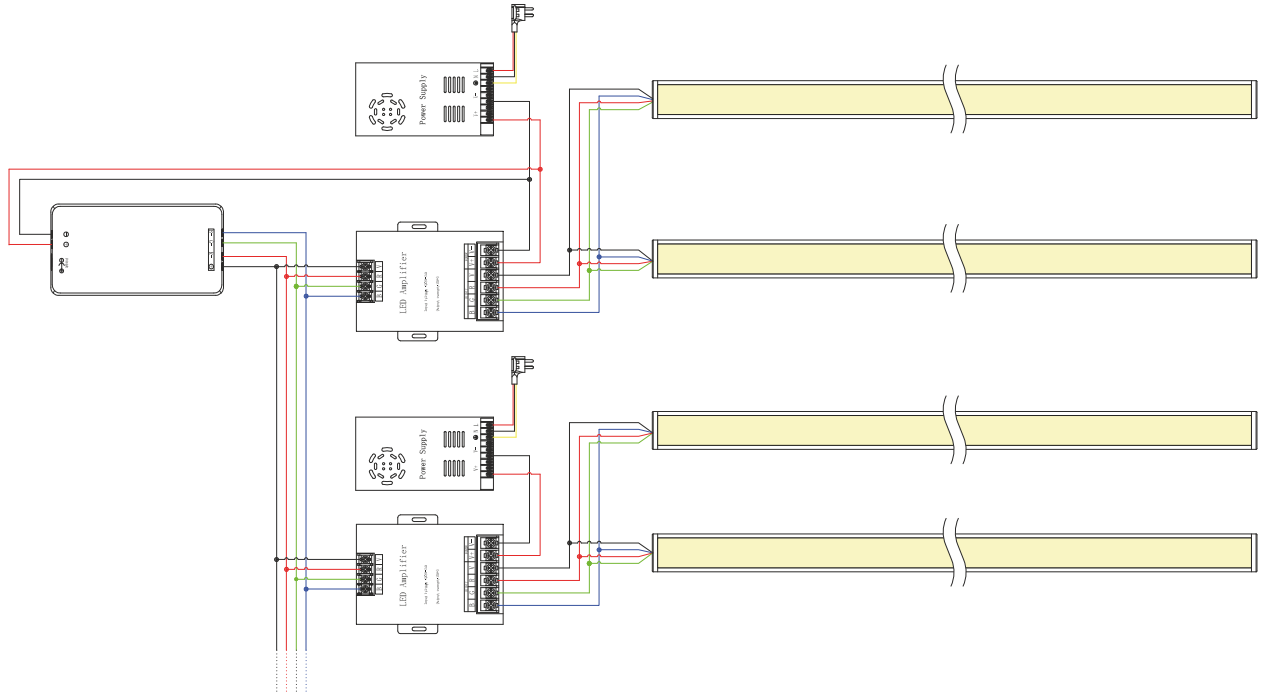

### RGBW Connection Diagram

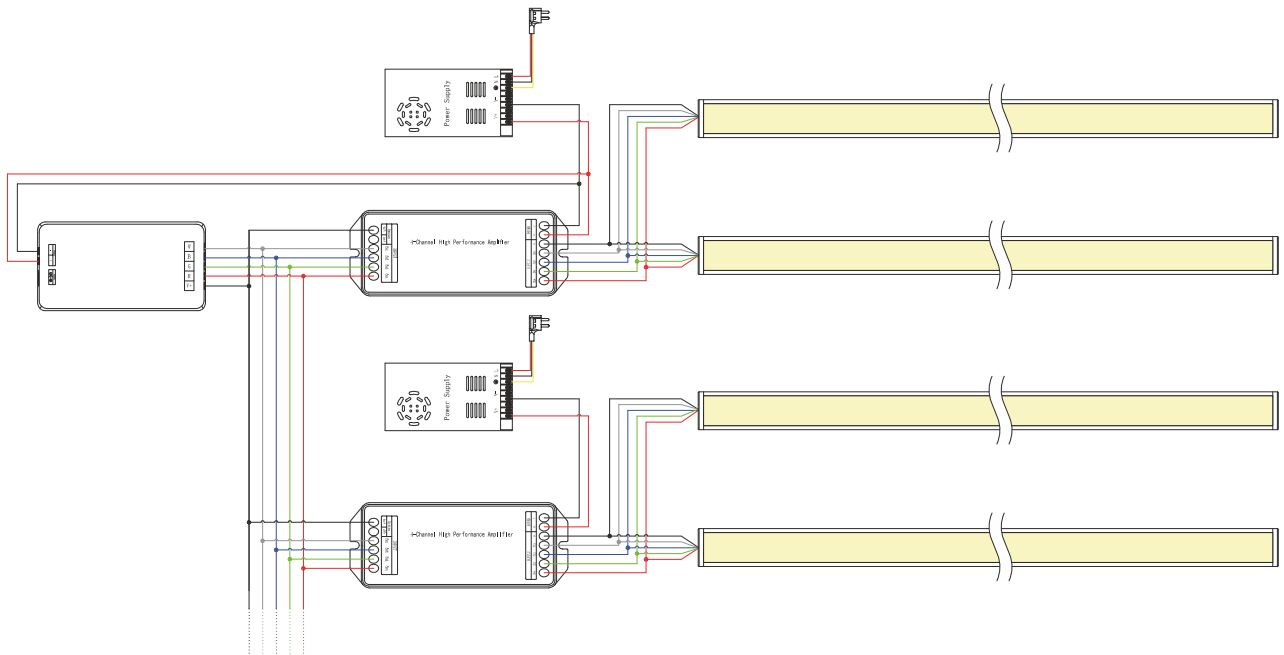

DMX512 Digital RGB Connection Diagram

Offline control

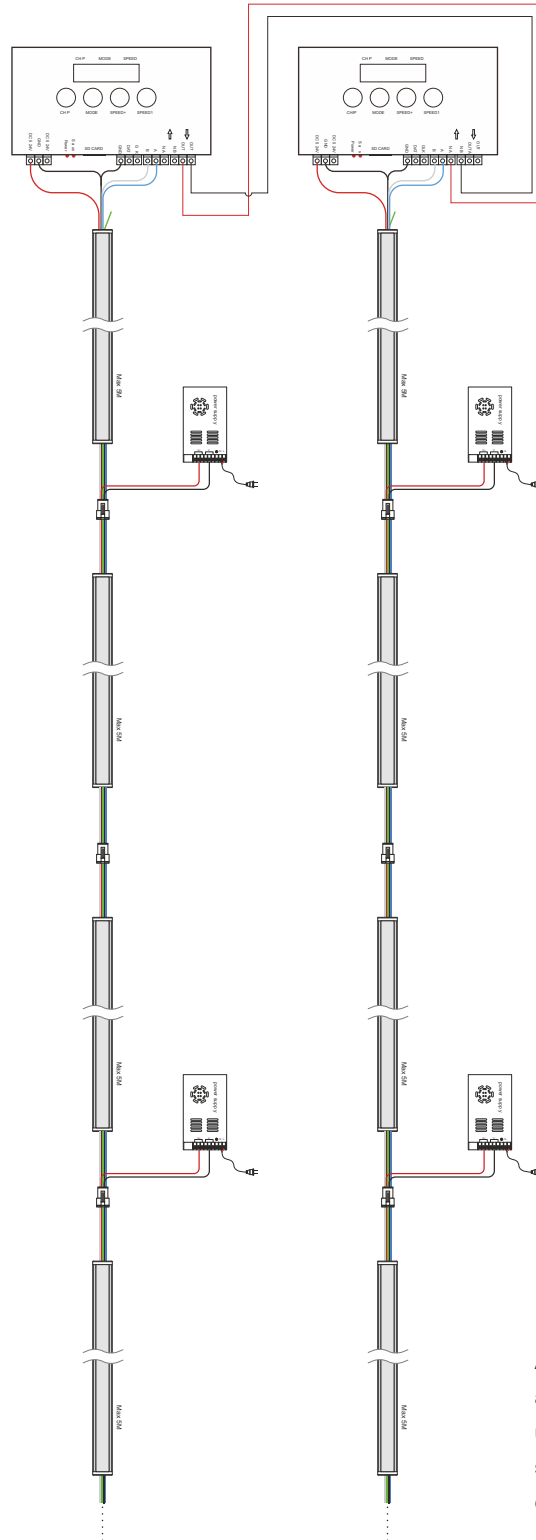

After the led strip is connected to the signal wire and power supply wire correctly, it is necessary to use a special addresser to address the led strip, then the controller / console can run the control effect program.



### Installation Steps

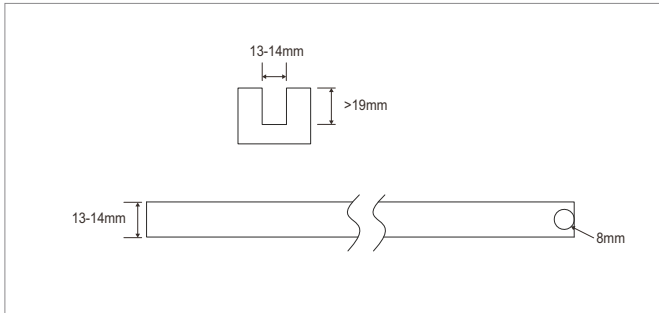

1. Make grooves and outlet holes according to the dimensions shown in the picture.

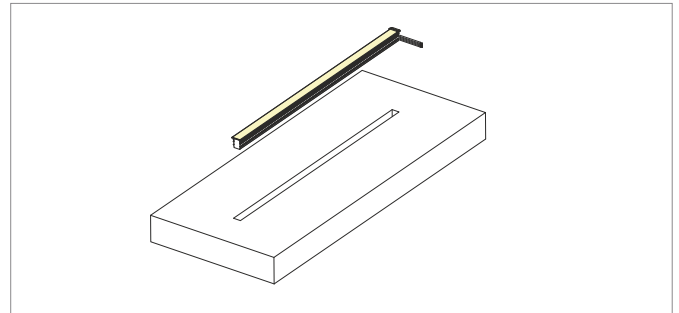

2. Pass the cable of the light through the reserved hole as shown in the figure.

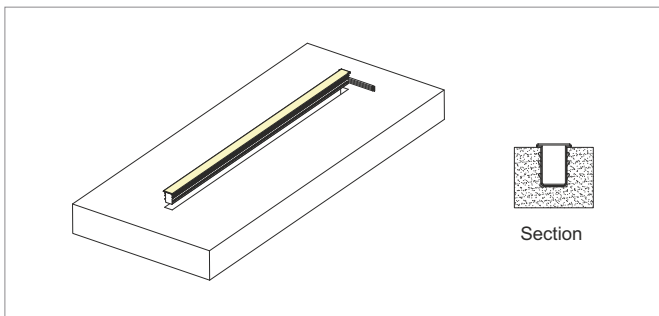

3. Align the light to the groove, press the glowing surface of the light, and fully embed the light into the groove.

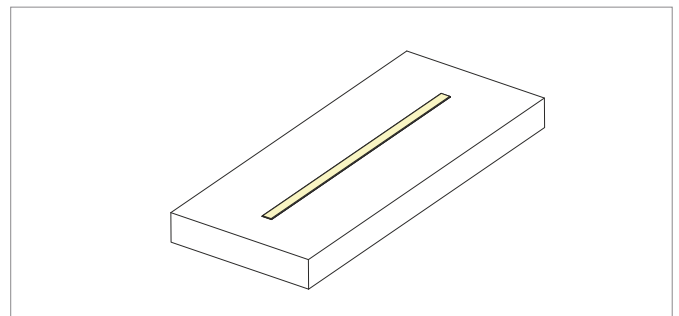

4. Completed.

**Cautions**

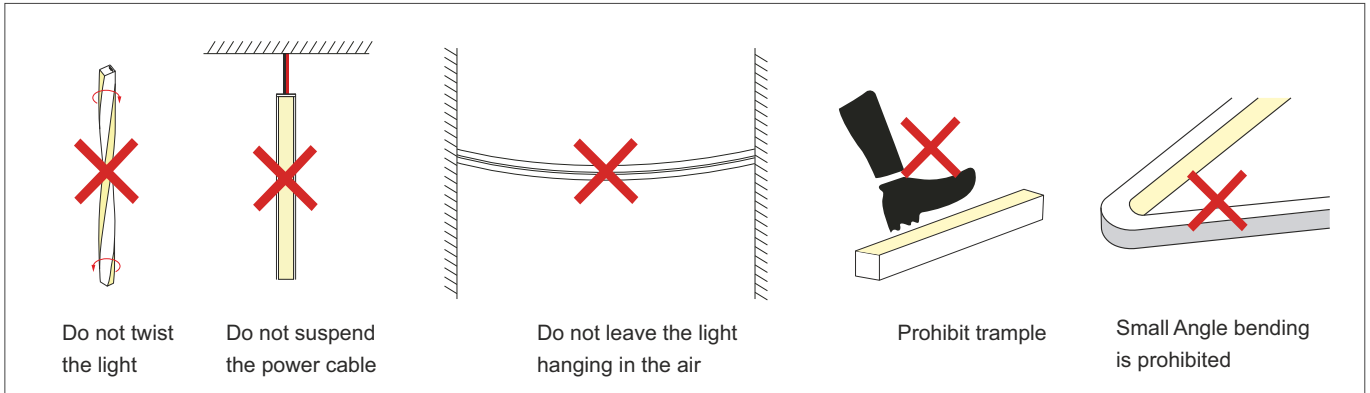

**Installation Precautions - Side Mounted** (If the length of the light is more than 2 meters, two persons must work together to install it.)

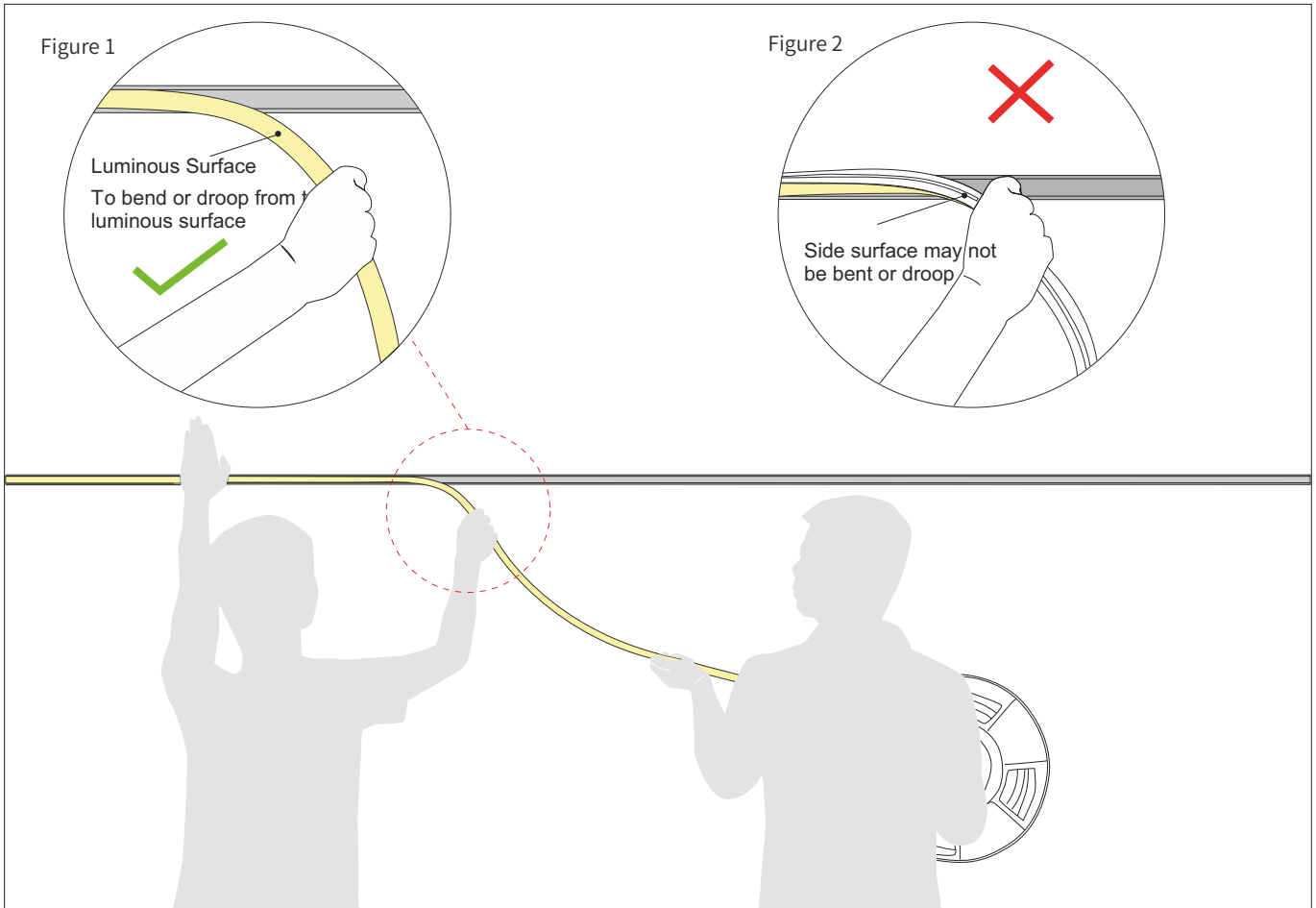

**1. Installer:**

Press the light with the palm of the left hand to slowly load it into the slot. Straighten the light with right hand so that it droop it in the direction of your hand. See Figure 1.

Side surface may not be bent or droop, See Figure 2.

**2. Assistant:**

Cooperate with the installer to lift the reel of the light, and then slowly deliver the light to installer. Do not pull or twist the light during the installation.

**Installation Precautions - Side Mounted** (If the length of the light is more than 5 meters, two persons must work together to install it.)

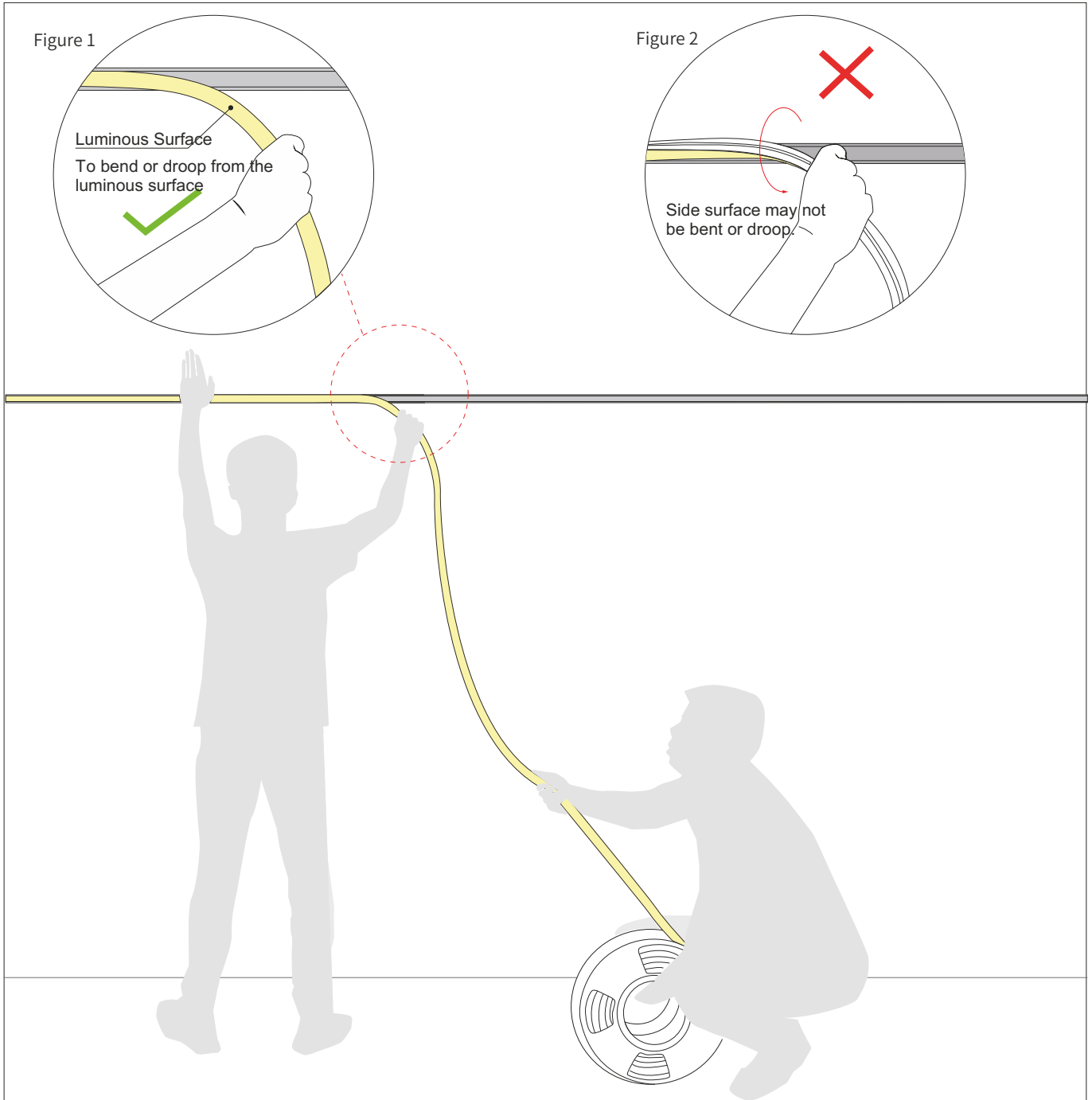

**1. Installer:**

Press the light with the palm of the left hand to slowly load it into the slot. Straighten the light with right hand so that it droop in the direction of your hand. See Figure 1.

Side surface may not be bent or droop, See Figure 2.

**2. Assistant:**

Cooperate with the installer to slowly deliver the light to installer. Do not pull or twist the light during the installation.

**Installation Precautions - Top Mounted** (If the length of the light is more than 2 meters, two persons must work together to install it.)

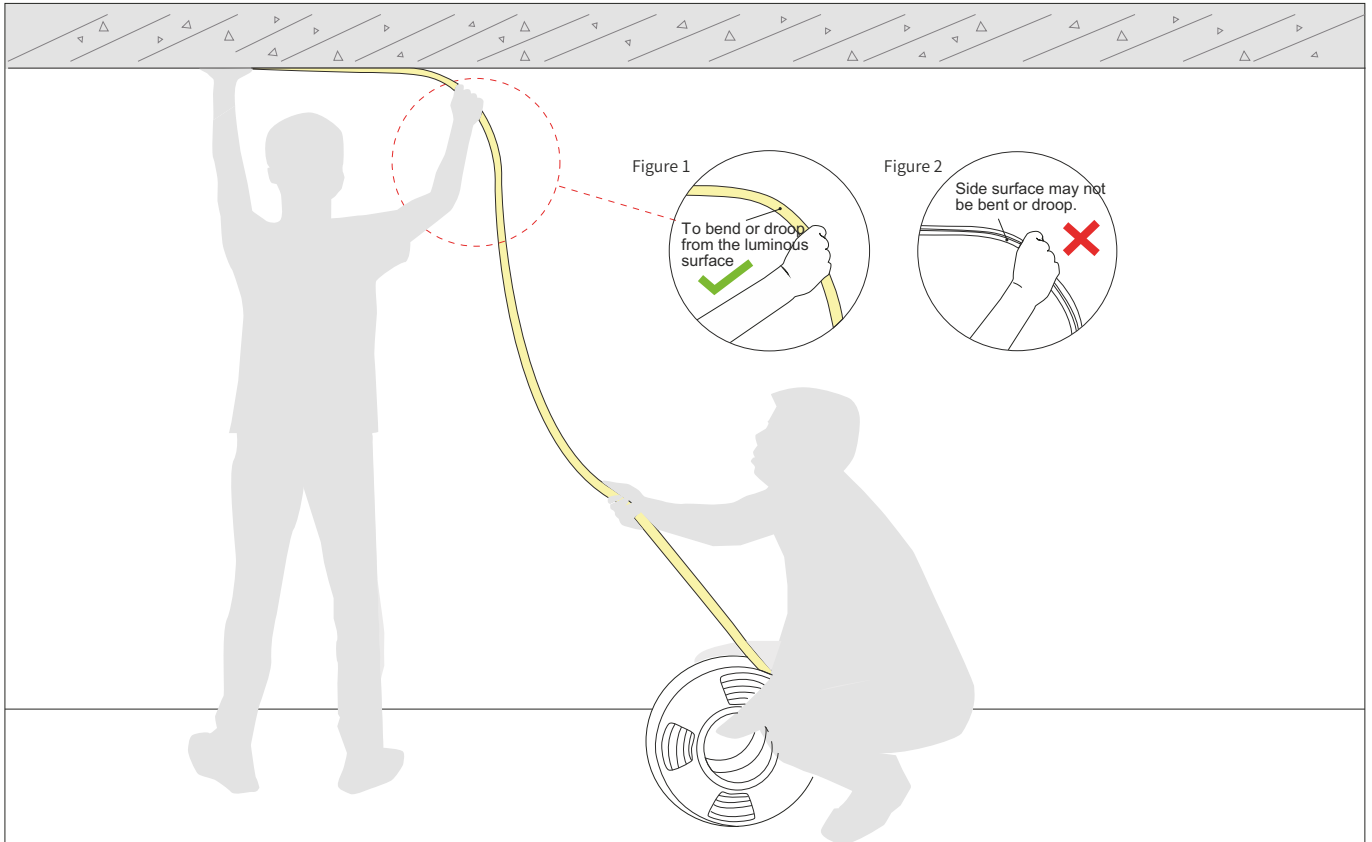

**1. Installer:**

Press the light with the palm of the left hand to slowly load it into the slot. Straighten the light with right hand, hold it and rotate it 90° to droop it in the direction of your hand. See Figure 1. Side surface may not be bent or droop, See Figure 2.

**2. Assistant:**

Cooperate with the installer to slowly deliver the light to installer. Do not pull or twist the light during the installation.

## Notes

Cooperate with the installer to slowly deliver the light to installer. Do not pull or twist the light during the installation.

Current of the light	Specifications of the cable								
	L=1M	L=2M	L=4M	L=6M	L=8M	L=10M	L=12M	L=14M	L=16M
1A	AWG26	AWG23	AWG21	AWG18	AWG18	AWG17	AWG16	AWG15	AWG15
2A	AWG23	AWG21	AWG18	AWG16	AWG15	AWG14	AWG13	AWG12	AWG12
3A	AWG22	AWG18	AWG16	AWG14	AWG13	AWG12	AWG11	AWG11	AWG10
4A	AWG21	AWG18	AWG15	AWG13	AWG12	AWG11	AWG10	AWG9	AWG9
5A	AWG20	AWG17	AWG14	AWG12	AWG11	AWG10	AWG9	AWG9	AWG8
6A	AWG18	AWG16	AWG13	AWG11	AWG10	AWG9	AWG8	AWG8	AWG7
7A	AWG18	AWG15	AWG12	AWG11	AWG9	AWG8	AWG8	AWG7	AWG6
8A	AWG17	AWG15	AWG12	AWG10	AWG9	AWG8	AWG7	AWG7	AWG6
9A	AWG17	AWG14	AWG11	AWG10	AWG8	AWG7	AWG7	AWG6	AWG5
10A	AWG16	AWG14	AWG11	AWG9	AWG8	AWG7	AWG6	AWG6	AWG5

- The unused light should be sealed with the packaging bag to avoid prolonged exposure.
- Please use DC24V isolated constant voltage power supply with ripple voltage less than 5%. Using other types of power supply may damage the light or cause other safety risks.
- In practical application, 20% allowance should be reserved for power supply to ensure the stability of power supply.
- It is recommended that professionals connect the power supply. Do not connect the power supply with live power to avoid electric shock.
- Please confirm whether the voltage of the power supply is consistent with the voltage of the light; Pay attention to the positive and negative poles of the power cord, do not connect wrong, so as not to cause product damage;
- When multiple power supplies are used, ensure that the positive poles of the power supply are not connected in parallel. Otherwise, the power supply system may be unstable or damaged after long-term operation.
- If the actual application length exceeds the specified length, it will lead to overload, heating and uneven brightness of the light.
- During installation, please do not scratch, twist or bend the light irregularly. Otherwise, the light may be damaged beyond repair.
- To ensure the life and reliability of the light, please do not over bend the light, which will damage the product itself.
- To protect your eyes, please avoid staring at the glowing surface of the light for a long time.
- Non professionals are forbidden to install, disassemble and maintain the product.
- Do not use any acid or alkaline adhesive to fix the light (including but not limited to glass glue, etc.)
- Because of the difference in structure, even if the same color temperature value, different sizes of light will look slightly different colors. Please confirm it before use.

In the newly decorated interior environment, epoxy floor paint, wall paint, wallpaper adhesive, various decoration materials or new furniture, they are likely to release of methanol and benzenes.

It is recommended to remove methanol and benzenes first, or ventilate for a period of time in the newly decorated interior environment before install the silicone neon light, to avoid affecting the silicone body.